

THIS SHEET INCLUDES FITTING INSTRUCTIONS FOR THE FOLLOWING PARTS:

Secondary Alternator Cover Part No. EC-R1-2009-1-GBR / Secondary Alternator Cover KIT Part No. EC-R1-2009-1-K-GBR /
Secondary Clutch Cover Part No. EC-R1-2009-2-GBR / Secondary Pulse Cover Part No. EC-R1-2009-3-GBR
Paddock Stand / Bobbin Set Part No. BA12-6-GBR-SET



SECONDARY ALTERNATOR COVER PART NO. EC-R1-2009-1-GBR

- 1 Remove 4 existing bolts from the stock Alternator cover, shown as position Bolt 1, 2, 3 & 4.
- 2 Place the Secondary Alternator Cover over the stock cover.
- 3 Assemble 4 replacement bolts loosely in the correct position as shown.
- 4 Tighten bolts to a Torque of 10Nm as per manufacturers recommendations.
DO NOT OVERTIGHTEN.

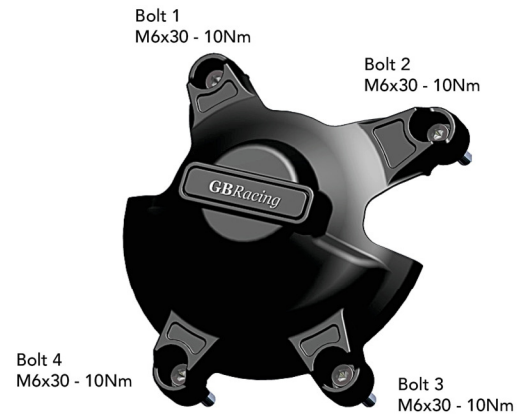
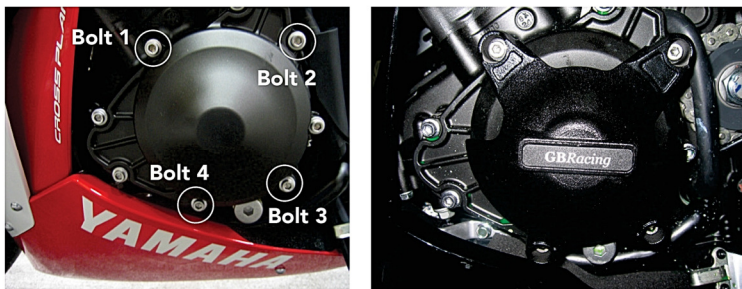

SECONDARY CLUTCH COVER PART NO. EC-R1-2009-2-GBR

- 1 Remove 4 existing bolts from the stock Clutch cover, shown as position Bolt 1, 2, 3 & 4.
- 2 Place the Secondary Clutch Cover over the stock cover.
- 3 Assemble 4 replacement bolts loosely in the correct position as shown.
- 4 Tighten bolts to a Torque of 10Nm as per manufacturers recommendations.
DO NOT OVERTIGHTEN.

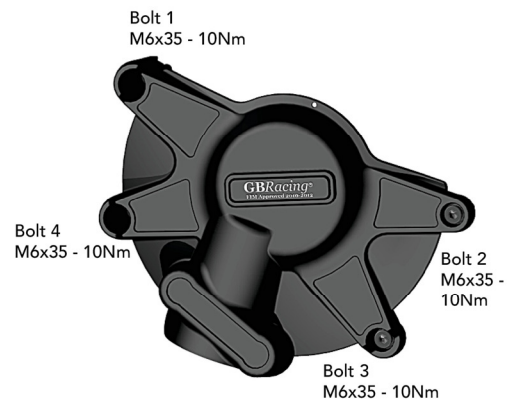
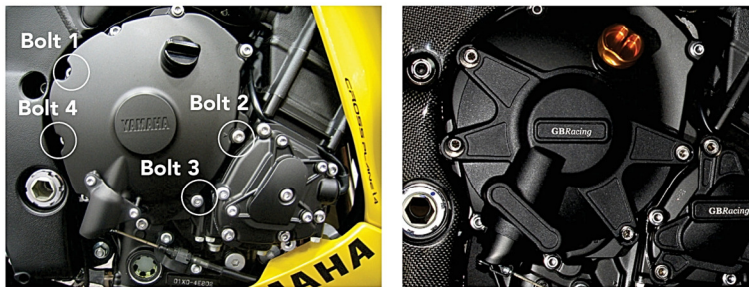

SECONDARY PULSE COVER PART NO. EC-R1-2009-3-GBR

- 1 Remove 3 existing bolts from the stock Pulse cover, shown as position Bolt 1, 2, & 3.
- 2 Place the Secondary Pulse Cover over the stock cover.
- 3 Assemble 3 replacement bolts loosely in the correct position as shown.
- 4 Tighten bolts to a Torque of 10Nm as per manufacturers recommendations.
DO NOT OVERTIGHTEN.

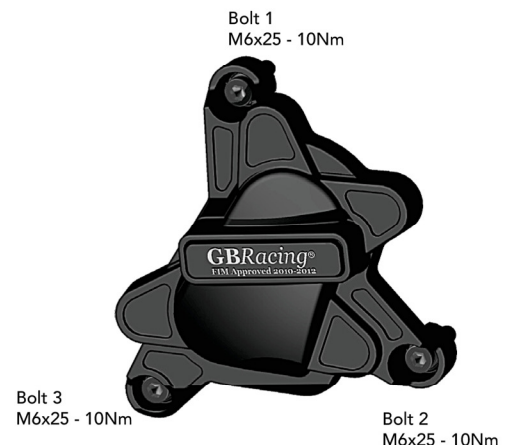
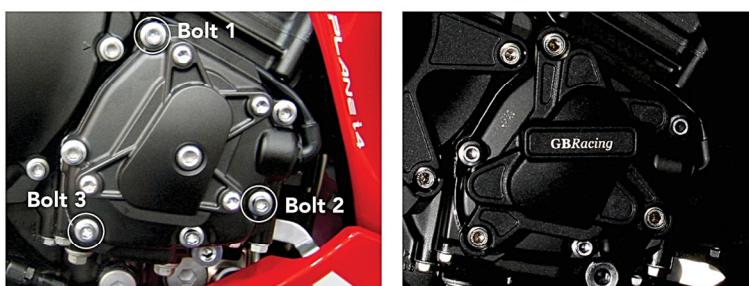

SECONDARY ALTERNATOR COVER - KIT - PART NO. EC-R1-2009-1-K-GBR

- 1 Remove 4 existing bolts from the stock Alternator cover, shown as position Bolt 1, 2, 3 & 4.
- 2 Place the Secondary Alternator Cover over the stock cover.
- 3 Assemble 4 replacement bolts loosely in the correct position as shown.
- 4 Tighten bolts to a Torque of 10Nm as per manufacturers recommendations.
DO NOT OVERTIGHTEN.

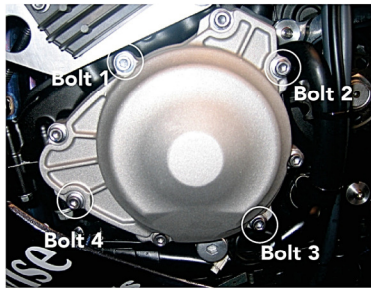

KIT ONLY

Bolt 1
M6x30 - 10Nm

Bolt 2
M6x30 - 10Nm



Bolt 4
M6x30 - 10Nm

Bolt 3
M6x30 - 10Nm

PADDOCK STAND / BOBBIN SET
PART NO. BA12-6-GBR-SET

- 1 Assemble M6 x 40mm Bolt & M6 Washer through the moulded bobbin.
- 2 Tighten bolts to swing arm boss, 8 Nm.
DO NOT OVERTIGHTEN

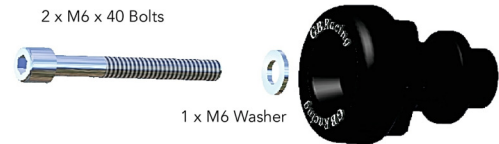

2 x M6 x 40 Bolts

1 x M6 Washer

1 x Moulded Paddock Stand / Bobbin